



Flygt D 8056, 50 Hz

Table of Contents

Technical Specification.....	2
Product description.....	2
Motor Rating and Performance Curves.....	5
LT.....	5
MT.....	6
HT.....	7
Dimensions and Weight.....	8
LT.....	8
MT, HT.....	9

Technical Specification

Product description

Usage

A submersible pump for corrosive wastewater containing solids or fibered material.

Denomination

Type	Non-explosion proof version	Explosion proof version	Pressure class	Installation types
Stainless steel	8056.280		<ul style="list-style-type: none"> • LT – Low head • MT – Medium head • HT – High head 	P, S

The pump can be used in the following installations:

- P Semi permanent, wet well arrangement with pump installed on two guide bars with automatic connection to discharge.
- S Portable semi permanent, wet well arrangement with hose coupling or flange for connection to discharge pipeline.

Application limits

Feature	Description
Liquid temperature	Maximum 40°C (104°F)
Depth of immersion	Maximum 20 m (65 ft)
pH of the pumped liquid	2 - 14
Liquid density	Maximum 1100 kg/m ³

Motor data

Feature	Description
Motor type	Squirrel-cage induction motor
Frequency	50 Hz
Power supply	3-phase
Starting method	<ul style="list-style-type: none"> • Direct on-line • Star-delta
Number of starts per hour	Maximum 30
Code compliance	IEC 60034-1
Voltage variation	<ul style="list-style-type: none"> • Continuously running: Maximum ±5% • Intermittent running: Maximum ±10%
Voltage imbalance between phases	Maximum 2%
Stator insulation class	H (180°C, 356°F)

Cables

Application	Type
Direct-on-line start	<p>Flygt SUBCAB® - a heavy duty 4 cores motor power cable with two twisted pair screened control cores. Conductor insulation rating of 90°C, which allows for increased current. Superior mechanical strength and high abrasion and tear resistant. Chemical resistant within pH 3-10 and ozone, oil, and flame resistant. Used up to 70°C water temperature. Cables < 10 mm² with unscreened control cores.</p> <p>Flygt SUBCAB® - a heavy duty 7 cores motor power cable with two twisted pair screened control cores. Conductor insulation rating of 90°C, which allows for increased current. Superior mechanical strength and high abrasion and tear resistant. Chemical resistant within pH 3-10 and ozone, oil, and flame resistant. Used up to 70°C water temperature. Cables < 7G6 mm² with unscreened control cores.</p> <p>Flygt HCR (Heat and Chemical Resistant) cable - a heavy duty 7 cores motor power cable. Conductor insulation rating of 150°C, which allows for increased current. Made of FEP and ETFE and resistant to chemicals and solvents, high temperature, and mechanical stress. Used up to 90°C water temperature and where high chemical resistance is required.</p>
Y/D start	<p>Flygt SUBCAB® - a heavy duty 4 cores motor power cable with two twisted pair screened control cores. Conductor insulation rating of 90°C, which allows for increased current. Superior mechanical strength and high abrasion and tear resistant. Chemical resistant within pH 3-10 and ozone, oil, and flame resistant. Used up to 70°C water temperature. Cables < 10 mm² with unscreened control cores.</p> <p>Flygt SUBCAB® - a heavy duty 7 cores motor power cable with two twisted pair screened control cores. Conductor insulation rating of 90°C, which allows for increased current. Superior mechanical strength and high abrasion and tear resistant. Chemical resistant within pH 3-10 and ozone, oil, and flame resistant. Used up to 70°C water temperature. Cables < 7G6 mm² with unscreened control cores.</p> <p>Flygt HCR (Heat and Chemical Resistant) cable - a heavy duty 7 cores motor power cable. Conductor insulation rating of 150°C, which allows for increased current. Made of FEP and ETFE and resistant to chemicals and solvents, high temperature, and mechanical stress. Used up to 90°C water temperature and where high chemical resistance is required.</p>

Monitoring equipment

Thermal contacts opening temperature 125° C (257° F)

Materials

Table 1: Major parts except mechanical seals

Denomination	Material	ASTM	EN
Major castings	Stainless steel	ASTM A 743 CF-8M	1.4408,1.4412,1.4581
Pump housing	Stainless steel	ASTM A 743 CF-8M	1.4408,1.4412,1.4581

Denomination	Material	ASTM	EN
Impeller	Stainless steel	ASTM A 743 CF-8M	1.4408,1.4412,1.4581
Lifting handle/schackle	Stainless steel	ASTM/AISI 316L	1.4404,1.4432, ...
Shaft	Stainless steel	ASTM/AISI 316L	1.4404,1.4432, ...
Screws and nuts	Stainless steel, A4	AISI 316L, 316, 316Ti, etc	1.4401,1.4404, ...
O-rings	Fluorinated rubber (FPM) 70 IRHD	-	-
Oil, part no 901752	Medical white oil of paraffin type. Fulfills FDA 172.878 (a)	-	-

Table 2: Mechanical seals

Inner seal	Outer seal
Carbon/ Aluminum oxide	Silicon carbide/ Silicon carbide

Surface treatment

None.

Options

- Other cables
- Flexible protective sheeting for the cables
- Zinc anodes, Surface treatment (Epoxy)
- Leakage sensor in the stator housing (FLS)
- Water detector in motor and oil housing

Accessories

- Discharge connections, adapters, hose connections, and other mechanical accessories.
- Electrical accessories such as pump controller, control panels, starters, monitoring relays, cables.

Motor Rating and Performance Curves

LT

Star-delta starting current is 1/3 of Direct on-line starting current.

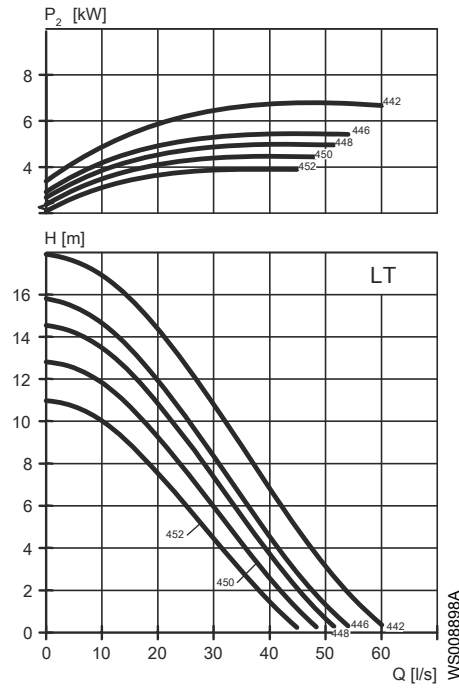

Table 3: 400 V, 50 Hz, 3-phase

Rated power, kW	Rated power, hp	Curve/ Impeller No	Revolutions per minute, rpm	Rated current, A	Starting current, A	Power factor, cos φ	Installation
7.5	10.1	442	1395	16	78	0.83	P,S
6.0	8.0	446	1385	13	57	0.85	P,S
5.0	6.7	448	1410	11	57	0.82	P,S
5.0	6.7	450	1410	11	57	0.82	P,S
5.0	6.7	452	1410	11	57	0.82	P,S

MT

Star-delta starting current is 1/3 of Direct on-line starting current.

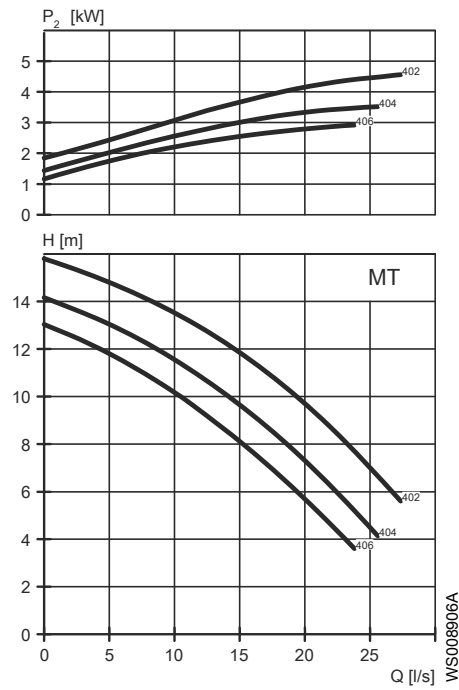

Table 4: 400 V, 50 Hz, 3-phase

Rated power, kW	Rated power, hp	Curve/ Impeller No	Revolutions per minute, rpm	Rated current, A	Starting current, A	Power factor, cos φ	Installation
7.5	10.1	402	1395	16	78	0.83	P,S
7.5	10.1	404	1395	16	78	0.83	P,S
7.5	10.1	406	1395	16	78	0.83	P,S
6	8	402	1380	13	57	0.85	P,S
6	8	404	1380	13	57	0.85	P,S
6	8	406	1380	13	57	0.85	P,S
5	6.7	402	1410	11	57	0.82	P,S
5	6.7	404	1410	11	57	0.82	P,S
5	6.7	406	1410	11	57	0.82	P,S

HT

Star-delta starting current is 1/3 of Direct on-line starting current.

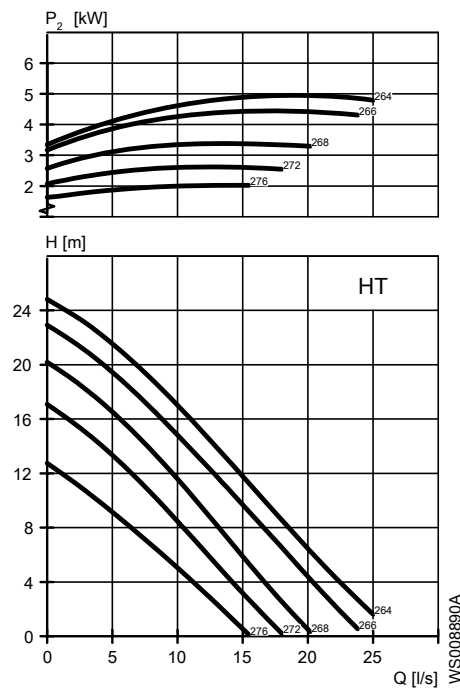

Table 5: 400 V, 50 Hz, 3-phase

Rated power, kW	Rated power, hp	Curve/ Impeller No	Revolutions per minute, rpm	Rated current, A	Starting current, A	Power factor, cos φ	Installation
5.0	6.7	264	2820	10	48	0.88	P,S
5.0	6.7	266	2820	10	48	0.88	P,S
5.0	6.7	268	2820	10	48	0.88	P,S
5.0	6.7	272	2820	10	48	0.88	P,S
5.0	6.7	276	2820	10	48	0.88	P,S

Dimensions and Weight

LT

All drawings are available as Acrobat documents (.pdf) and AutoCad drawings (.dwg).
Contact your local sales and service representative for more information.

All dimensions are in mm.

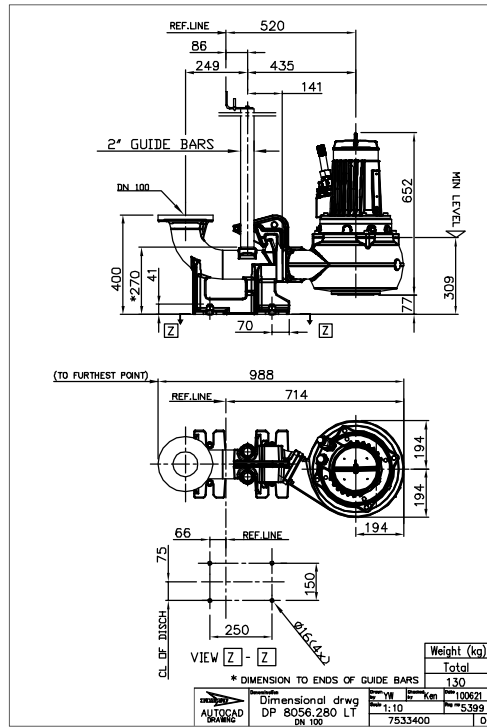

Figure 1: LT, P-installation

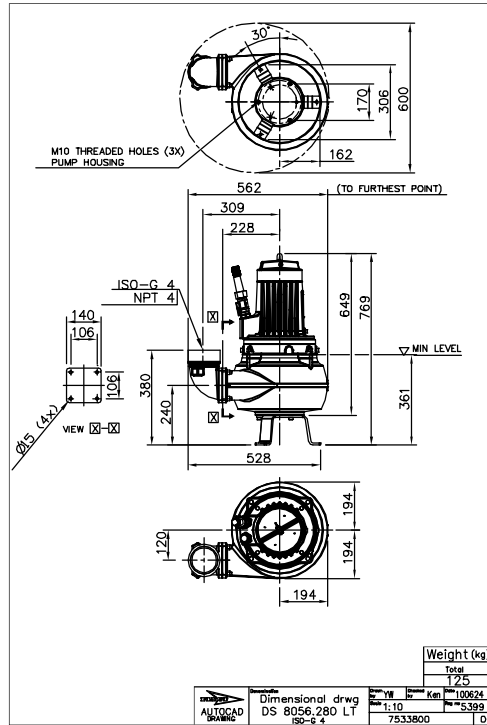

Figure 2: LT, S-installation

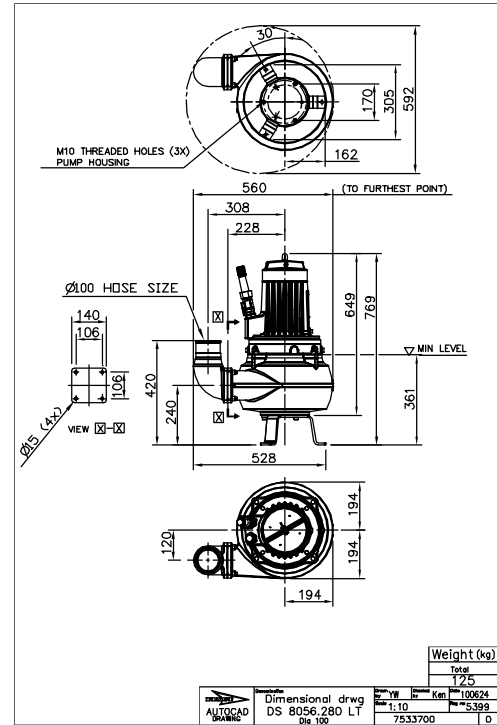

Figure 3: LT, S-installation

MT, HT

All drawings are available as Acrobat documents (.pdf) and AutoCad drawings (.dwg). Contact your local sales and service representative for more information. All dimensions are in mm.

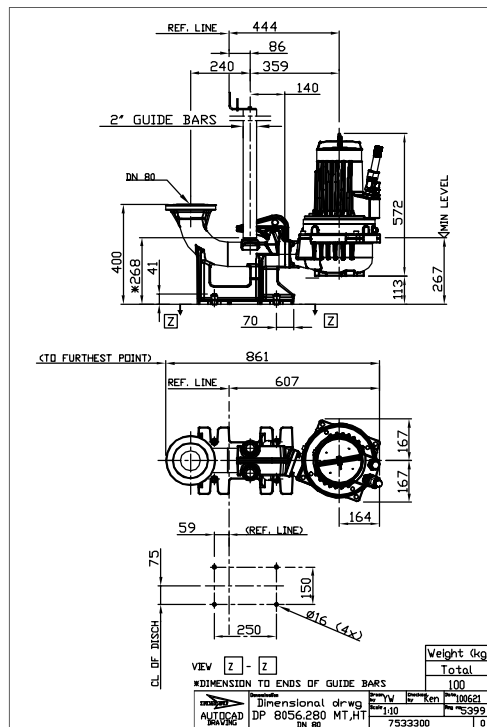

Figure 4: MT, HT, P-installation

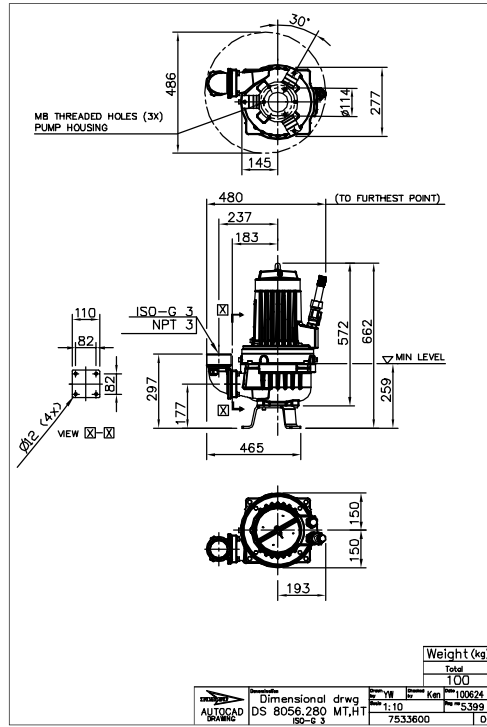

Figure 5: MT, HT, S-installation

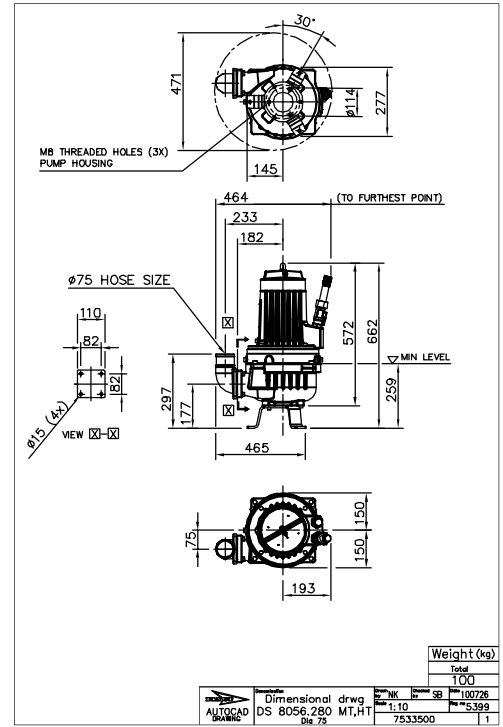

Figure 6: MT, HT, S-installation



ООО «Бауманс Груп» - официальный партнер фирмы Flygt в России.

Тел: +7 495 121 49 50

Эл. почта: info@baumgroup.ru

Сайт: www.baumgroup.ru